

Candidate ID No;

Name:

**NPTEL course on Mechanics of Solids
April-June 2015**

Certification exam :: Duration: 3 hrs :: Maximum: 100 marks

INSTRUCTIONS:

- 1. Allotted space only will be graded.**
2. Use backside of all the pages are for rough work.
3. Support your answers with proper illustrations such as **freebody diagrams** wherever possible
4. Each one of the six problems carries equal marks.

| 1. | 2. | 3. | 4. | 5. | 6. | Total |
|-----------|-----------|-----------|-----------|-----------|-----------|--------------|
| | | | | | | |

1. A cylinder of radius r and mass m rests on a horizontal plank. The plank is suddenly pulled with an acceleration a horizontally as shown. Assume no slipping occurs between the plank and the cylinder.

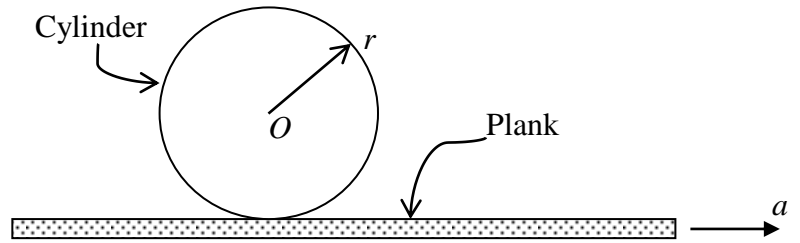

Draw the freebody diagram of the cylinder.

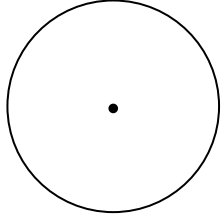

Draw the diagram with kinetic quantities

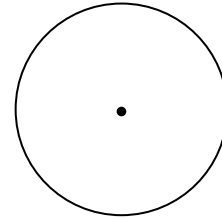

List the unknown quantities

Write down the kinematic relations here

Write down the kinetic equations here

Find linear & angular accelerations of cylinder

2. A cylinder is rotating at a speed ω of 1750rpm when the light handbrake system is applied using force $F(t) = (10t+300)$ N with t in seconds as shown. The dynamic coefficient friction between the belt and the cylinder is 0.3. The radius of gyration of cylinder is 200mm and of mass 500kg.

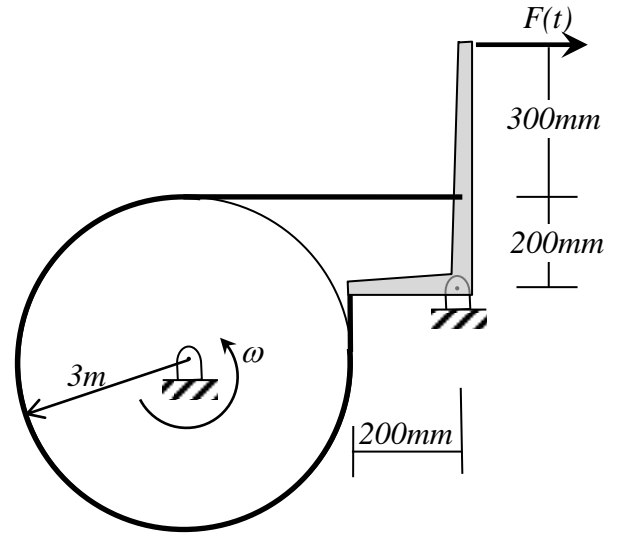

- a. Draw the freebody diagrams of the cylinder and the handbrake lever

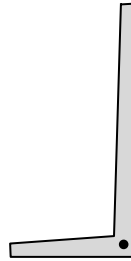
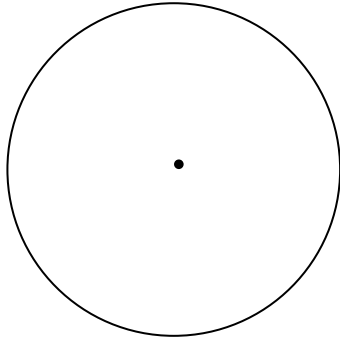

- b. Identify the unknown quantities – forces and accelerations.

- c. Write down the appropriate equations pertaining to equilibrium and motion.

- d. Solve for deceleration of the cylinder.

- e. Compute the time taken for the time taken to reduce the speed of the cylinder to half it's original.

3. Two uniform rods, each of mass m and length L are welded together to form the assembly shown. The spring constant of each spring is k and that end A is given a small displacement and released.

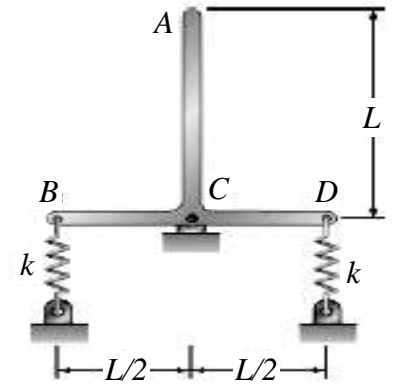

- a. Draw the freebody diagram and the diagram with kinetic (inertial) quantities when set to motion.

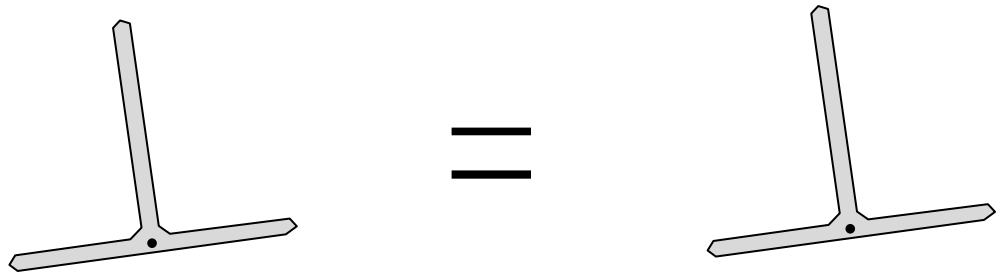

- b. Write the equation of motion pertaining to the resulting motion.

- c. Reduce the above to an equation pertaining to a simple harmonic motion

- d. and derive the angular frequency of motion.

4. A beam ABCD supported at B and C is loaded as shown.

- a) Draw the Shear force diagram (SFD) and the bending moment diagram (BMD) in the space marked below the figure as SFD and BMD.

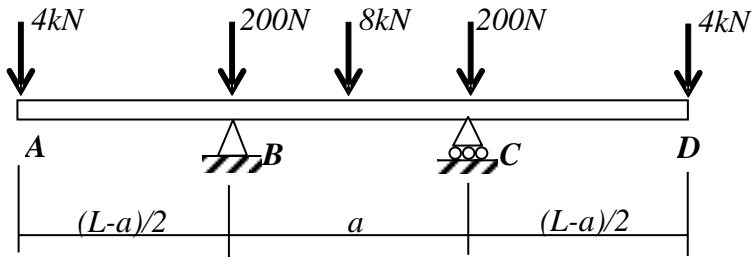

SFD

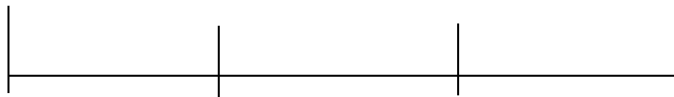

BMD

- b) If the supports at B and C can be moved, find the value of a (in terms of L) for which the maximum of the magnitude of the bending moment will be the least.

5. Shown below is a truss system with two pinned (hinged) supports at A and B.

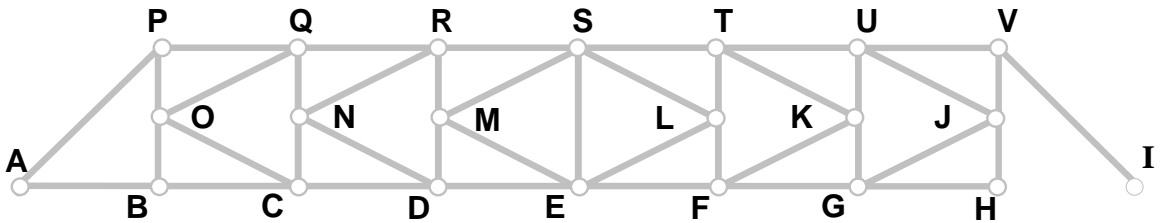
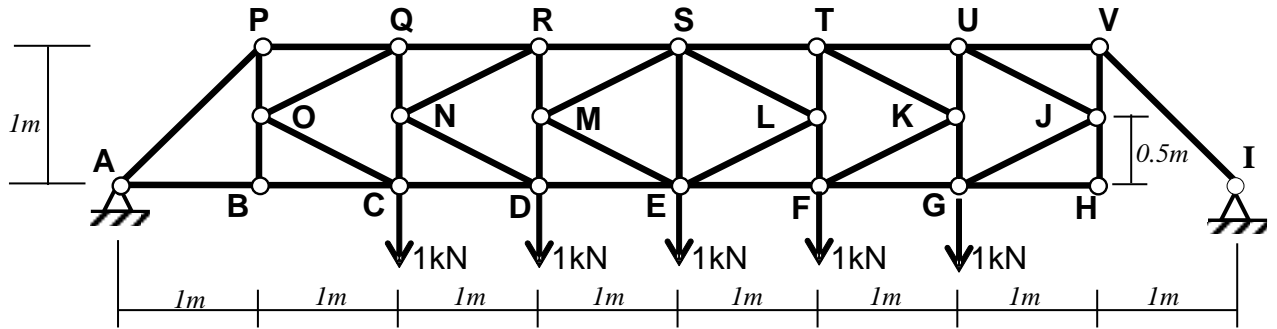

(use the above diagram for drawing the free body)

| | | | |
|---|---|--|--|
| a) Find support reactions at A: | b) Find support reactions at I: | | |
| c) Internal force in QR: | d) Internal force in CD: | | |
| e) What is the nature of force in FG (tension /or compression?) | f) What is the nature of force in TU (tension /or compression?) | | |
| g) Zero force members are (list all of them) | | | |
| | | | |
| | | | |
| | | | |
| | | | |
| | | | |

6. Answer the following. Be brief and to the point.

- a. It is found that the direction of velocities of the ends A and B of the bar shown coincide at a particular instant of time. The magnitudes of the velocities are unknown. What all could be inferred from this information?



- b. A mass m is attached to the end A of a massless rod AC of length $2l$ that can only rotate about B as shown. The current position of the mass is at y_A with respect to the datum as shown. Find the virtual work done by the mass m in terms of a small virtual change $\delta\theta$ in θ as the mass virtually goes up by a small extent, δy_A .

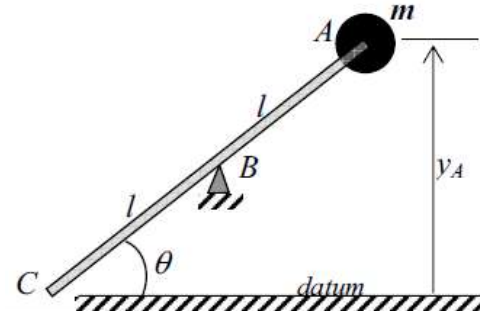

- c. The top shown rotates at a constant velocity of ω about its axis (z , say) and at the same time making a steady precession at an angle θ as shown (z axis revolves around Y forming a cone of angle θ). The distance of the centre of gravity from the bottom tip is h along its axis. Find the angular momentum vector of the top.

